

AMERICAN AVK RESILIENT SEATED GATE VALVE TAPPING ASSEMBLY 55/7X
250 PSI, Tested to AWWA C515 (NRS), - Valve Sizes 18" - 24"
Flanged to ANSI B16.1 class 125, & Mechanical Joint to AWWA C111

55/7X
TAPPING

Use:

For water and neutral liquids to maximum 160°F.

Tests:

Hydraulic test to AWWA C515:
Seat Test: 250 PSI

Options:

Handwheel
Electric Actuator
Bevel Gear
Spur Gear
304 & 316 Hardware

Standard Materials:

Spool Pieces,	Ductile iron ASTM A536
Coating	Electrostatically applied fusion-bonded epoxy-resin Meets or exceeds AWWA C550
Hardware	Zinc plated steel
Valve	Series 55/5X

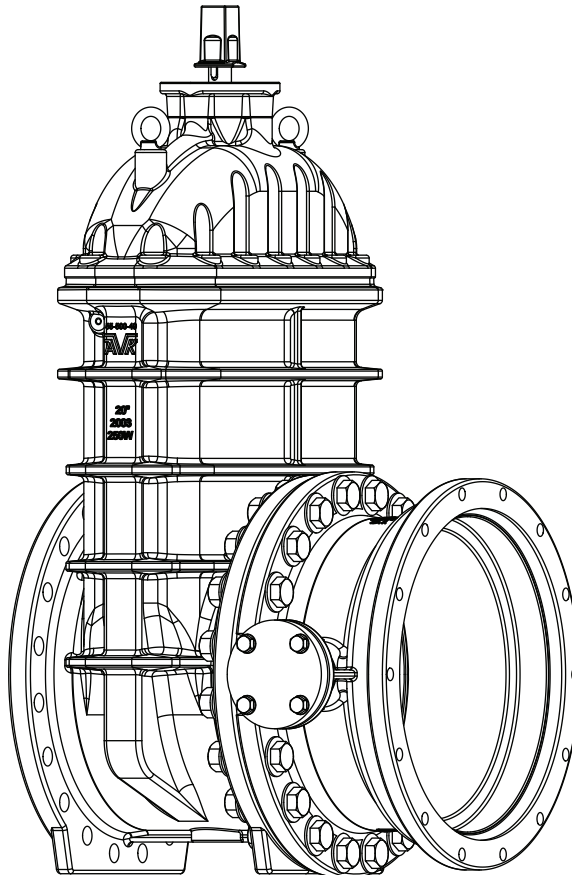

AMERICAN AVK RESILIENT SEATED GATE VALVE TAPPING ASSEMBLY 55/7X
250 PSI, Tested to AWWA C515 (NRS), - Valve Sizes 18" - 24"
Flanged to ANSI B16.1 class 125, & Mechanical Joint to AWWA C111

55/7X
TAPPING

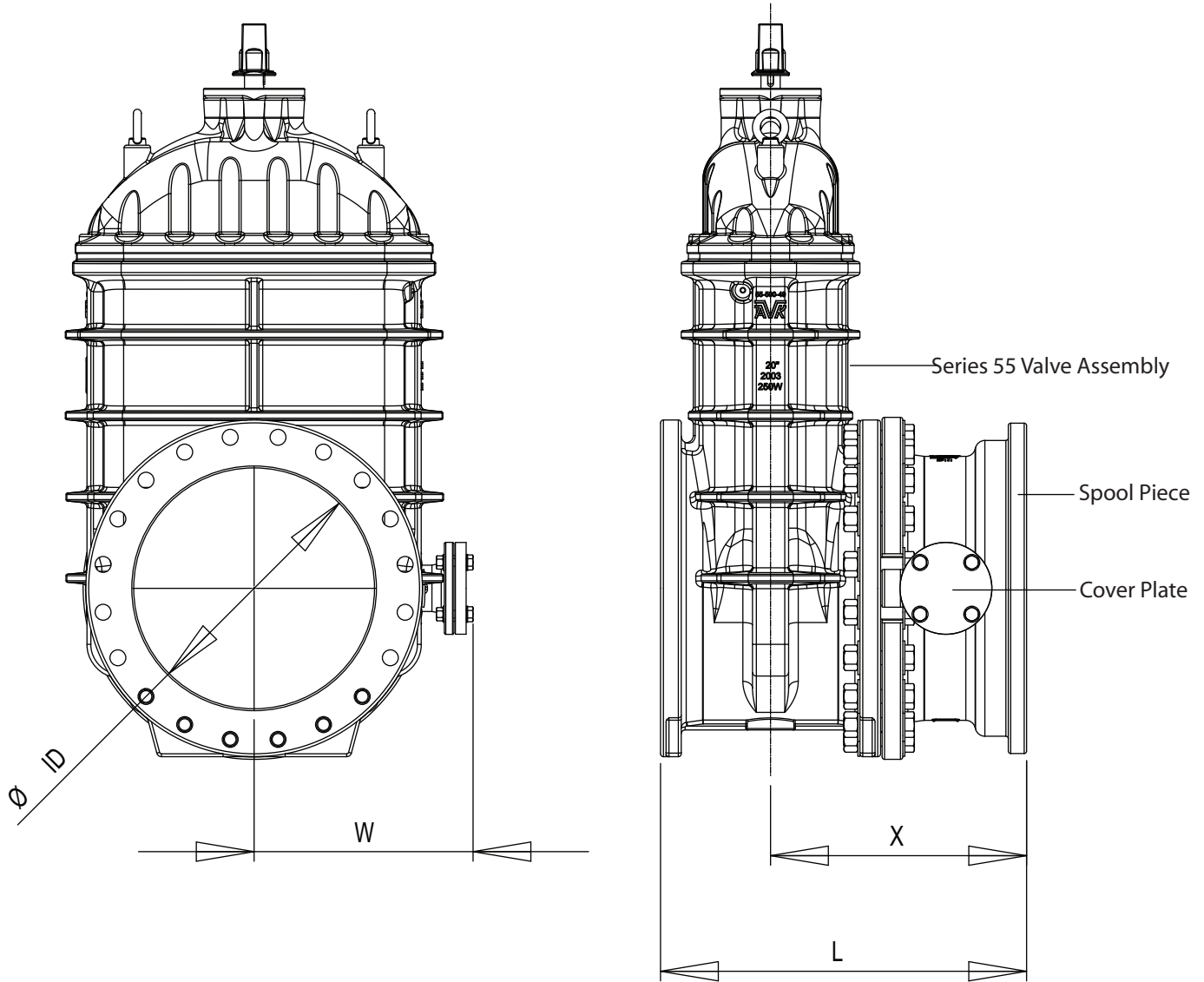

Ref. nos	Size/ID	L	W	X	Lateral Size
55-450-7X	18"	28.00"	16.80"	19.50"	3"
55-500-7X	20"	29.80"	18.00"	20.80"	3"
55-600-7X	24"	33.00"	20.50"	23.00"	4"

