

AMERICAN AVK RESILIENT SEATED GATE VALVE
250 PSI, Tested to AWWA C515 (OS&Y)
Flange Ends to ASME B16.42 Class 150 - Valve Sizes 18" - 24"

55/FFO
FLxFL

Use:

For water and neutral liquids to maximum 160°F.

Tests:

Hydraulic test to AWWA C515:

Shell Test: 500 PSI

Seat Test: 250 PSI

Operating Torque Test

Standard Materials:

Body, Bonnet, Yoke, Gland Follower Ductile iron ASTM A536

Coating Electrostatically applied fusion-bonded epoxy-resin
Meets or exceeds AWWA C550

Stem Aluminum Bronze

Wedge Ductile iron ASTM A536
encapsulated with EPDM-rubber compound

Wedge Nut, Gland Gland Bushing Bronze

Bonnet Bolts, Yoke Bolts/Studs, Yoke Washers/Nuts Stainless Steel -316

Lifting Eyes Zinc plated steel

Bonnet Gasket, EPDM rubber

O-Ring Stem Seals, O-Ring Gland Seal ASTM D2000 Buna "N" nitrile rubber

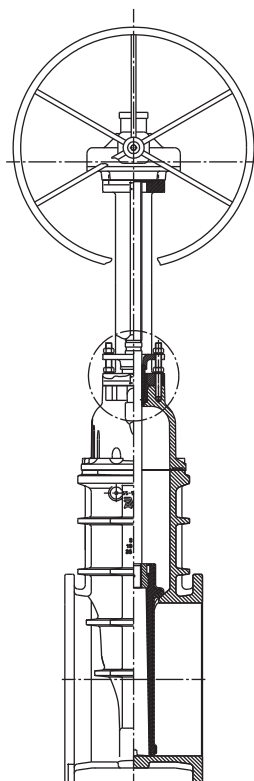

AMERICAN AVK RESILIENT SEATED GATE VALVE
250 PSI, Tested to AWWA C515 (OS&Y)
Flange Ends to ASME B16.42 Class 150 - Valve Sizes 18" - 24"

55/FFO
FLxFL

Component List:

204. Yoke	212. Inner Bushing O-ring	219. Body
206. Gland Follower/Yoke Nut	213. OS&Y Bushing	232. Lower Stem Seal O-ring
207. Gland Follower/Yoke Washer	214. Outer Bushing O-ring	238. Eye Bolt
208. Gland Follower	215. OS&Y Stem Assembly	250. Shoe
209. Gland	216. Bonnet Bolts	256. Yoke Bolt
210. Stud Bolt	217. Bonnet	256. Yoke Bolt Washer
211. Stem Seal O-rings	218. Bonnet Gasket	

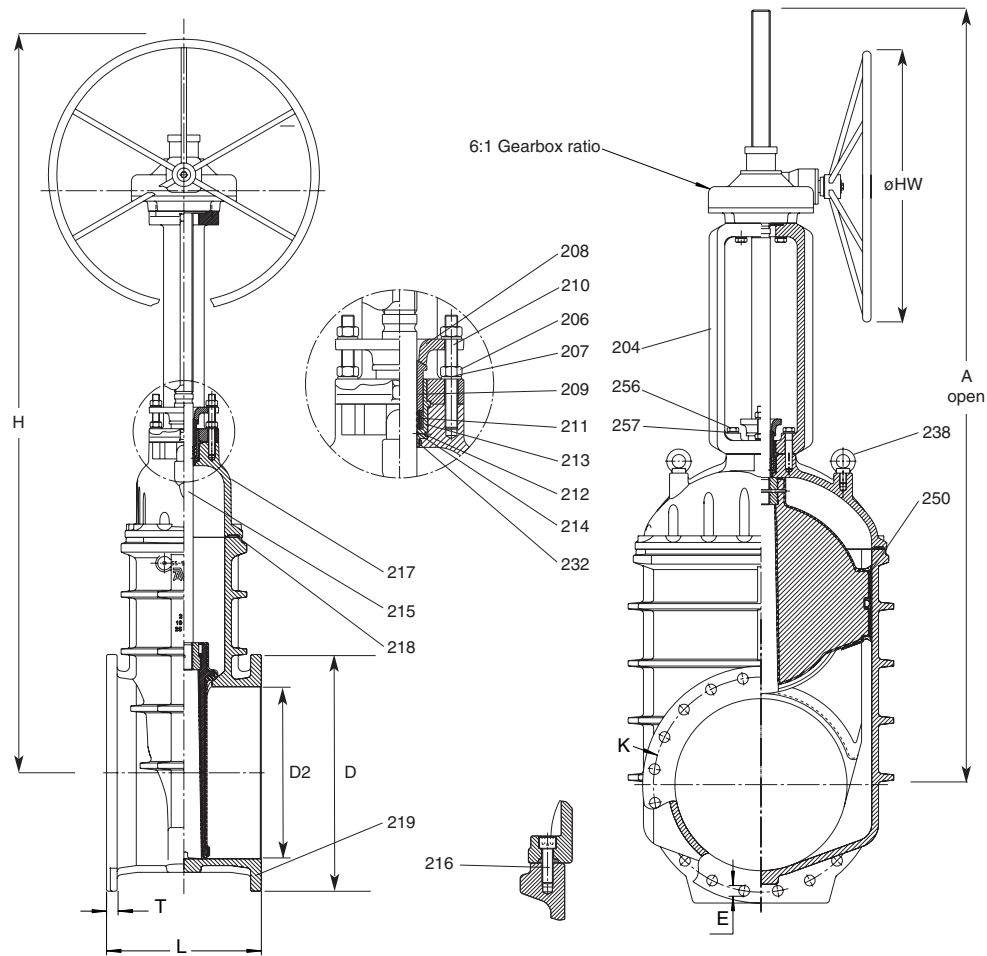

Ref. nos	Size	A open	D	D2	E	H	HW	K	L	T	Flange Holes	Turns to open	Wt. Lbs.
55-450-FFO	18"	90.10"	25.00"	18.00"	1.25"	84.50"	31.50"	22.75"	17.00"	1.56"	16	252	1513
55-500-FFO	20"	90.10"	27.50"	20.00"	1.25"	85.25"	31.50"	25.00"	18.00"	1.70"	20	252	1568
55-600-FFO	24"	101.20"	32.00"	24.00"	1.38"	91.35"	31.50"	29.50"	20.00"	1.90"	20	306	1800

