



FlowGuard II® Installation

American AVK Company
an ISO 9001 registered company

WARNING: For all of the following repair procedures, the hydrant must be isolated or the system depressurized and drained before removing the hydrant components. Failure to do so may cause pressure to be released resulting in severe injury or death.

1. Turn the Body (F128) up-side-down and set it down. The cast-in flow arrow should be pointing toward the Hard stable surface. Place the Ball (F132), into the Body.
2. Install the 8mm thick Seat Ring O-ring (F144), (the thickest of the three o-rings in the kit) onto the stainless steel Lower Seat Ring (F130), and grease the o-ring with a food grade grease that contains no acetate or silicone.
3. Place the Lower Seat Ring into the body and press into place. Ensure that the O-ring remains in it's proper location.
4. Use food grade grease that contains no acetate or silicone, to stick the Lower O-ring (F145), in the groove between the Body and the Lower Seat Ring.
5. Carefully turn the assembly over and place it on the mounting flange of the riser pipe and attach loosely with mounting hardware. The bolts should be installed from the bottom so that with the nuts are on top of the check valve flange.
6. Place the Upper O-ring (F143) into the groove in the top of the Body (F128).
7. Place the Upper Retaining Cage (F129) on to the top of the assembly and install the Cage O-ring (F146) into the groove in the top of the Upper Retaining Cage.
8. Carefully mount the Wet barrel assembly onto the FlowGuard II assembly with the Breakable Flange (F124) and mount with the mounting hardware as shown in Fig. 7B and Fig. 7C.
9. Carefully rotate the Wet barrel to the desired position. Do not dislodge the Upper O-ring, and tighten all mounting hardware to 60 Ft. Lbs. .
10. To ensure proper function, verify that the Body (F128) is buried or supported with concrete, up to the bury line marked on the body. See Fig, 7A & 7C

Included in Kit:

F30	Mounting Bolt	Qty.	12
F31	Mounting Washer	Qty.	24
F34	Mounting Nut	Qty.	12
F124	Breakable Flange	Qty.	1 pair
F128	Body	Qty.	1
F129	Upper Retainer Cage	Qty.	1
F130	Lower Seat Ring	Qty.	1
F132	FlowGuard II® Ball	Qty.	1
F143	Upper O-ring	Qty.	1
F144	Seat Ring O-ring	Qty.	1
F145	Lower O-ring	Qty.	1
F146	Cage O-ring	Qty.	1

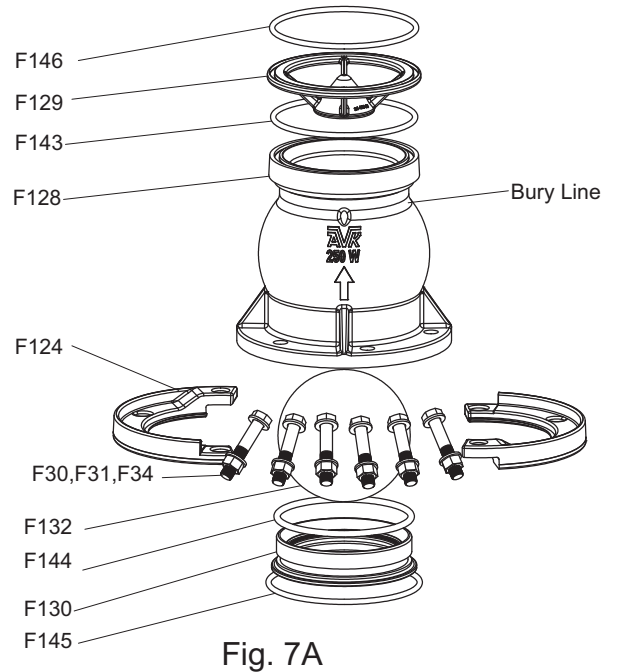

Fig. 7A

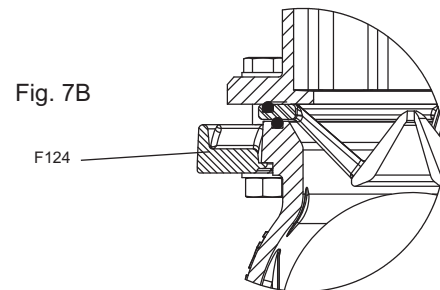

Fig. 7B

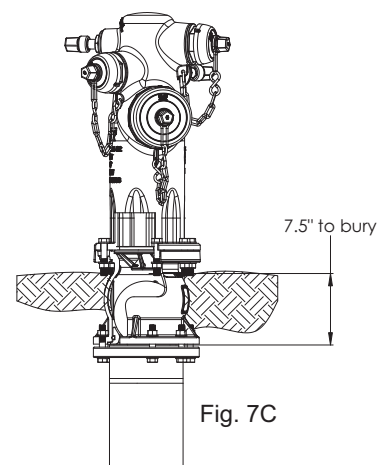

Fig. 7C