

**AVK SERIES 24 - HIGH PRESSURE,
WET BARREL HYDRANT
FIELD MAINTENANCE AND
INSTRUCTION MANUAL**

TABLE OF CONTENTS

- EXPLODED ASSEMBLY / PARTS LIST**
- INTRODUCTION / DESCRIPTION**
- RECEIVING AND STORAGE**
- INSTALLATION AND TESTING**
 - INSTALLATION
 - TESTING
- OPERATION AND MAINTENANCE**
 - HYDRANT TOOLS
 - OPERATION
 - MAINTENANCE PROCEDURES
 - INSPECTION
 - DISASSEMBLY FOR INSPECTION
 - REASSEMBLY AFTER INSPECTION
- REPAIR PROCEDURES**
 - TRAFFIC REPAIR KIT
- OPTIONAL EQUIPMENT**
 - FLOWGUARD
- TROUBLESHOOTING GUIDE**
- PARTS AND SERVICE**
- WARRANTY**

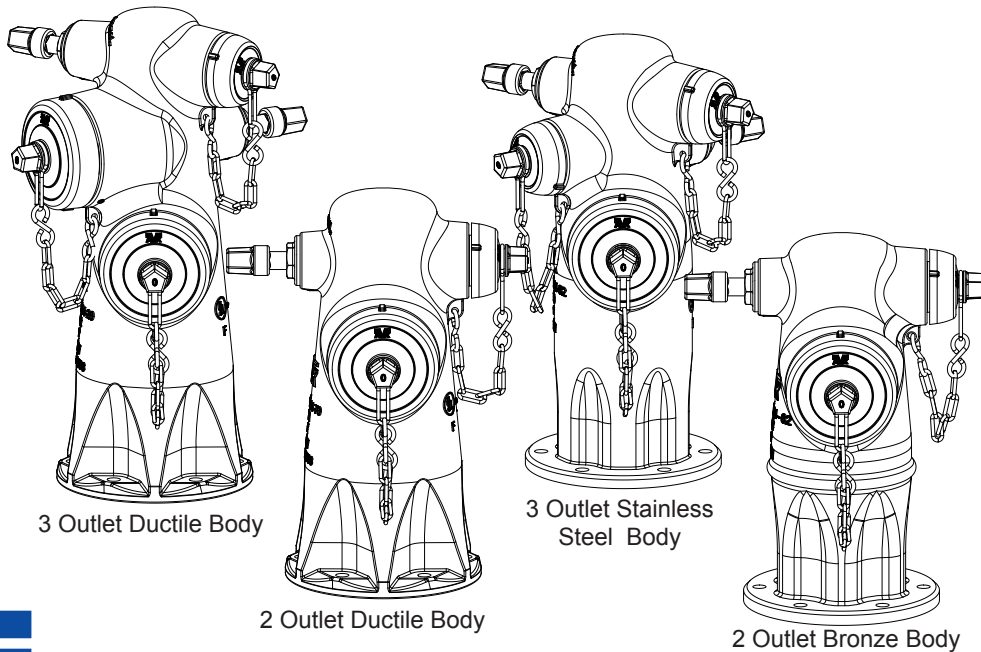

American AVK Series 24 Wet Barrel Hydrant Exploded Parts Breakdown

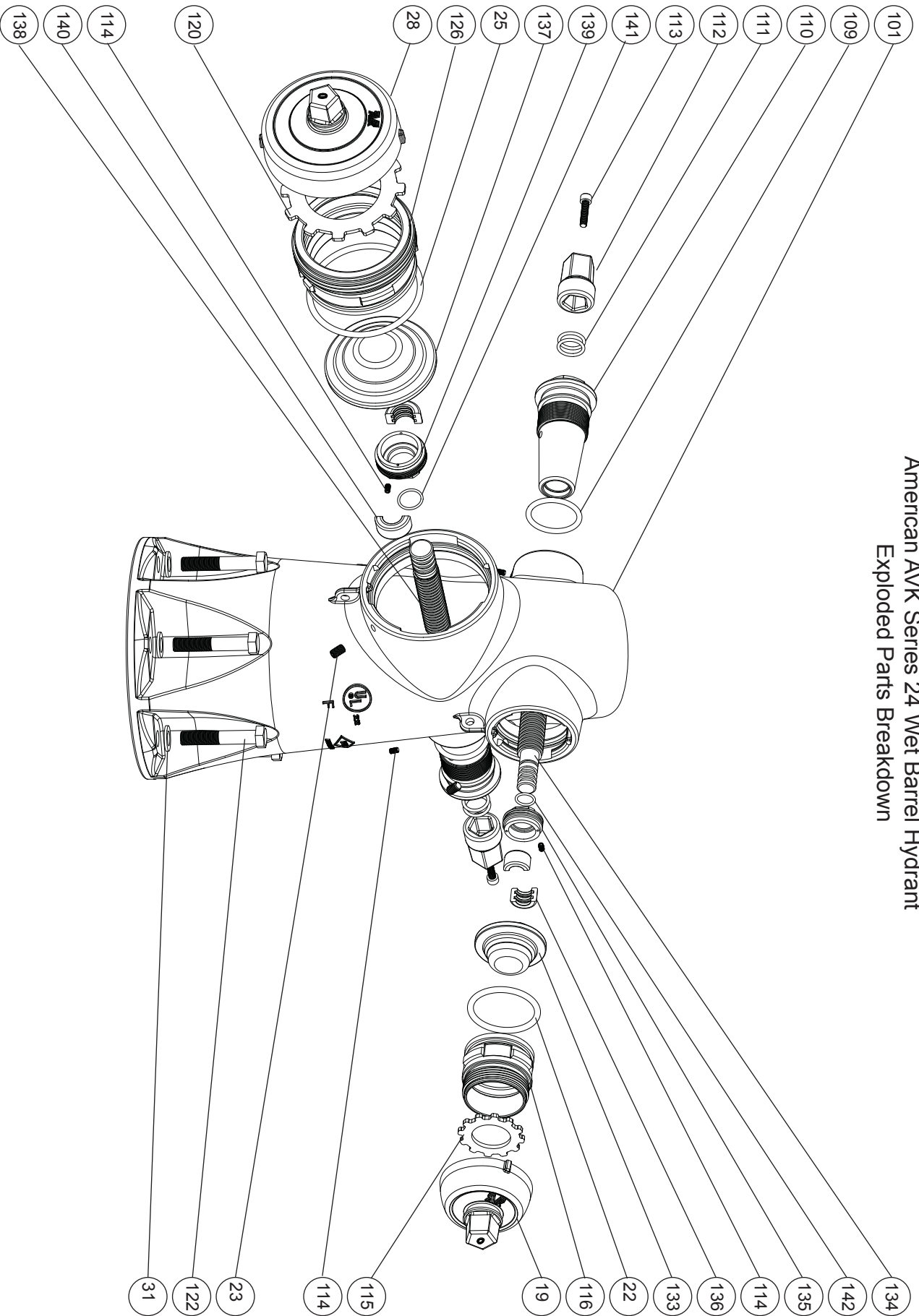

Item No.	Description	Material
19	Hose Nozzle Cap	Grey iron, ASTM A126, "B"
22	Hose Nozzle O-ring	NBR
23	Nozzle Retaining Screw	304 Stainless steel
24*	Chain Set	Zinc Plated steel
25	Pumper Nozzle O-ring	NBR
28	Pumper Cap	Grey iron, ASTM A126, "B"
31	Nozzle Section Washer	Zinc Plate, 304,316 Stainless steel
101	Nozzle Section	Ductile Iron, ASTM A536
109	Outer Stem Nut O-ring	NBR
110	Stem Nut	Copper Alloy
111	Inner Stem Nut O-ring	NBR
112	Dummy Nut	Grey iron, ASTM A126, "B"
113	Dummy Nut Retaining Bolt	304 Stainless steel
114	Stem/Thrust Nut Retaining Screw	304 Stainless steel
115	Hose Nozzle Cap Gasket	NBR, Neoprene
116	Hose Nozzle	Copper Alloy
120	Pumper Cap Gasket	NBR, Neoprene
122	Nozzle Section Bolt	Zinc Plate, 304,316 Stainless steel
126	Pumper Nozzle	Copper Alloy
133	2.5" Valve Disc	EPDM encapsulated ductile iron
134	2.5" Valve Stem	Copper Alloy
135	2.5" Thrust Nut	Copper Alloy
136	2.5" Thrust Collar	304 Stainless steel
137	4.5" Valve Disc	EPDM encapsulated ductile iron
138	4.5" Valve Stem	Copper Alloy
139	4.5" Thrust Nut	Copper Alloy
140	4.5" Thrust Collar	304 Stainless steel
141	4.5" Thrust Nut O-ring	NBR
142	2.5" Thrust Nut O-ring	NBR

* Not Shown

INTRODUCTION / DESCRIPTION

The American AVK Series 24 Wet Barrel Hydrant is designed to be a trouble free, easy to maintain hydrant. This manual will provide you with the information needed to properly install and maintain the fire hydrant and to ensure a long service life. The series 24 ductile iron Wet Barrel Hydrant is rated for a working pressure of 200 psi, is UL listed and FM approved, and meets or exceeds the requirements of AWWA C503, Standard for Wet Barrel Fire Hydrants, (where applicable). The stainless steel Wet Barrel Hydrant is rated for a working pressure of 200 psi, is UL listed. UL and FM do not list or approve the bronze Wet Barrel Hydrants.

American AVK series 24 Wet Barrel Hydrants are manufactured using three major materials. Ductile iron for general installations, 304 stainless steel for use in industrial or corrosive environments, and bronze, for coastal, or environments in or near air containing higher salt contents. The AVK Series 24 hydrant and hydrant tools are designed so that one person can perform all routine repairs and maintenance outlined in this manual.

NOTE: The repair and maintenance procedures in this manual are interchangeable for the standard ductile, stainless steel, and bronze hydrants. Unless otherwise stated, the figures in this manual depict the standard ductile nozzle sections.

American AVK also provides an additional series 24 model, the 2472, high pressure threaded nozzle hydrant, that has a rated working pressure of 250 psi. that is UL listed and FM approved, and an AWWA rated working pressure of 350 psi. Please refer to the Series 2472 maintenance manual for the threaded nozzle procedures.

RECEIVING AND STORAGE

Inspect the hydrants upon receipt for damage in shipment. Note any damage on the bill of lading and have the driver sign it. Notify American AVK. Unload all of the hydrants carefully to avoid damage. Verify that the hydrants have the correct direction to open, the correct nozzle configuration and threads, the correct operating nut size and shape, the correct depth of bury, and the correct inlet connection. Hydrants should remain clean and dry, and the main valve should be closed until installed to prevent weather related damage. For long term storage the hydrants should be stored indoors.

INSTALLATION AND TESTING

NOTE: American AVK recommends AWWA Standard C600 and AWWA Manual M17 for further information regarding hydrant installation and testing.

NOTE: Consult local codes and standards for proper fire hydrant placement and spacing

WARNING: All water lines must be isolated or depressurized and drained before installing or maintaining fire hydrants. Failure to do so may cause pressure to be released resulting in severe injury or death.

INSTALLATION

Correct installation of the Series 24 Wet Barrel Hydrant is important for proper operation. The following steps are general installation guidelines for a standard AVK Series 24 fire hydrant. Local conditions may require variations.

1. Before installing a hydrant, check to make sure all bolts are tight and all nozzles are properly installed (See NOZZLE INSTALLATION). Clean any dirt and debris from inside the hydrant base and from the hydrant lead.
2. The Pumper Nozzle (F126) should always face the street to provide a quick connection for the Fire Department.
3. The traffic section (Breakable Flange, (F124) should be set so it remains 2" above grade. The Breakable Flange also allows 360 degree positioning of the Nozzle Section.

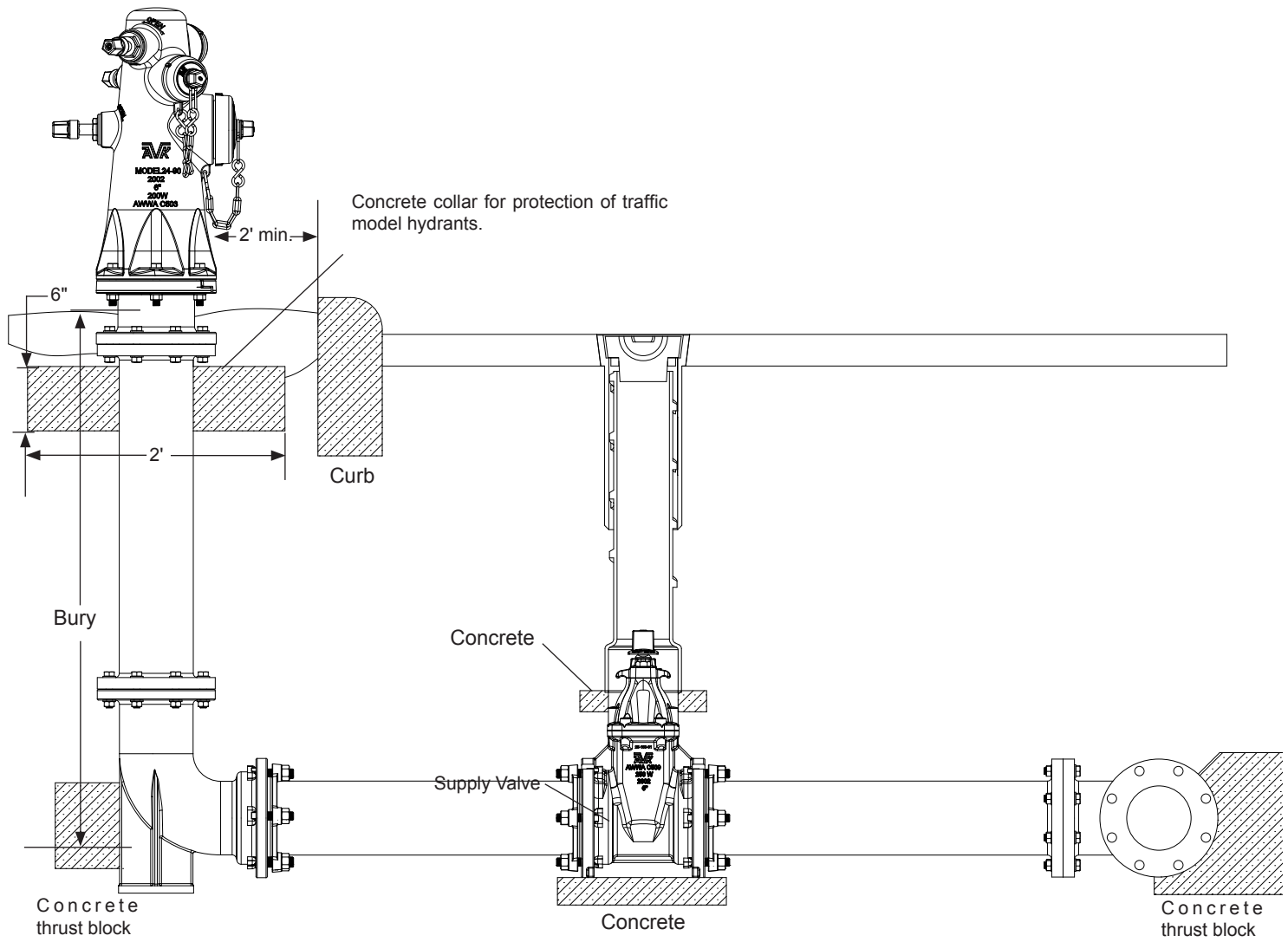

Fig. 1
 Hydrant Installation

PRESSURE TESTING

American AVK Hydrants are factory tested to 400 PSI. Should a field test be required it may be done in the following manner.

CAUTION: Prior to pressure testing, verify that all outlet and pumper valves have been fully closed! All American AVK Wet Barrel Hydrants close by turning the operating stems in a clockwise direction.

1. Remove one of the hose caps (F19).
2. Install a hydrant test cap with gauge, Slightly open the valve by turning in a “counterclockwise” direction, and bleed off the remaining air.
3. Verify security of the nozzle caps and open the hydrant to full line pressure.
4. If a higher test pressure is needed (max. 200 PSI working pressure for all AVK wet barrel hydrants, except the model 2472X, which has an AWWA rated working pressure of 350 PSI, and is UL listed 250 PSI), it can be reached by connecting a pressure test pump to the hydrant’s Pumper Nozzle (F126).

OPERATION AND MAINTENANCE

HYDRANT TOOLS

1. AVK Operating Wrench (Wet Barrels) Part Number: 24-150-30-400

METRIC AND INCH WRENCH REQUIREMENTS FOR AMERICAN AVK WET BARREL HYDRANTS

PART	INCH SIZE	METRIC SIZE
Dummy Nut Retaining Bolt (Allen)	15/64"	6mm
Stem Nut Retaining Screw (Allen)	7/64"	N/A
Nozzle Retaining Screw	3/16"	5mm
Nozzle Section Bolts and Nuts	15/16"	24mm

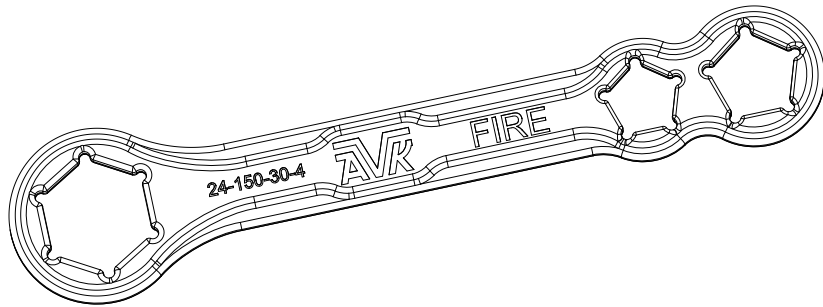

AVK Wet Barrel
Operating Wrench
24-150-30-400

OPERATION AND MAINTENANCE

OPERATION

American AVK Series 24 Wet Barrel Hydrants are factory tested and lubricated and require minimum maintenance, but all fire hydrants should be inspected for obvious damage, opened fully and flowed, at no less than once a year. Local maintenance services may require more frequent testing cycles.

WARNING: All hydrant hose outlet and pumper valves should be in the fully closed position while not in use. Always insure that the Water Main Supply Valve is open after any maintenance procedure has been performed.

1. Verify that all of the hydrant outlets are fully closed. Note that all AVK Wet Barrel Hydrants are manufactured in the "Open Left", configuration. (See Fig. 2.)
2. Remove the desired outlet Hose Cap (F19), or Pumper Cap (F28), using the AVK Hydrant Wrench or adjustable hydrant wrench.
3. Connect the desired apparatus to the hydrant. Slowly open the desired outlet by turning the 2.5" Valve Stem (F134), or 4.5" Valve Stem (F138) counter clockwise, using the AVK Hydrant Wrench or adjustable hydrant wrench on the Dummy Nut (F112).
4. Turn the stem in the clockwise direction to close the desired valve and shut water flow off.

CAUTION: After the hydrant has been turned off, carefully remove the hose or apparatus and visually verify that the hydrant valve is fully closed and no debris is preventing full valve closure.

5. Replace the Hose or Pumper Cap using the hydrant wrench.

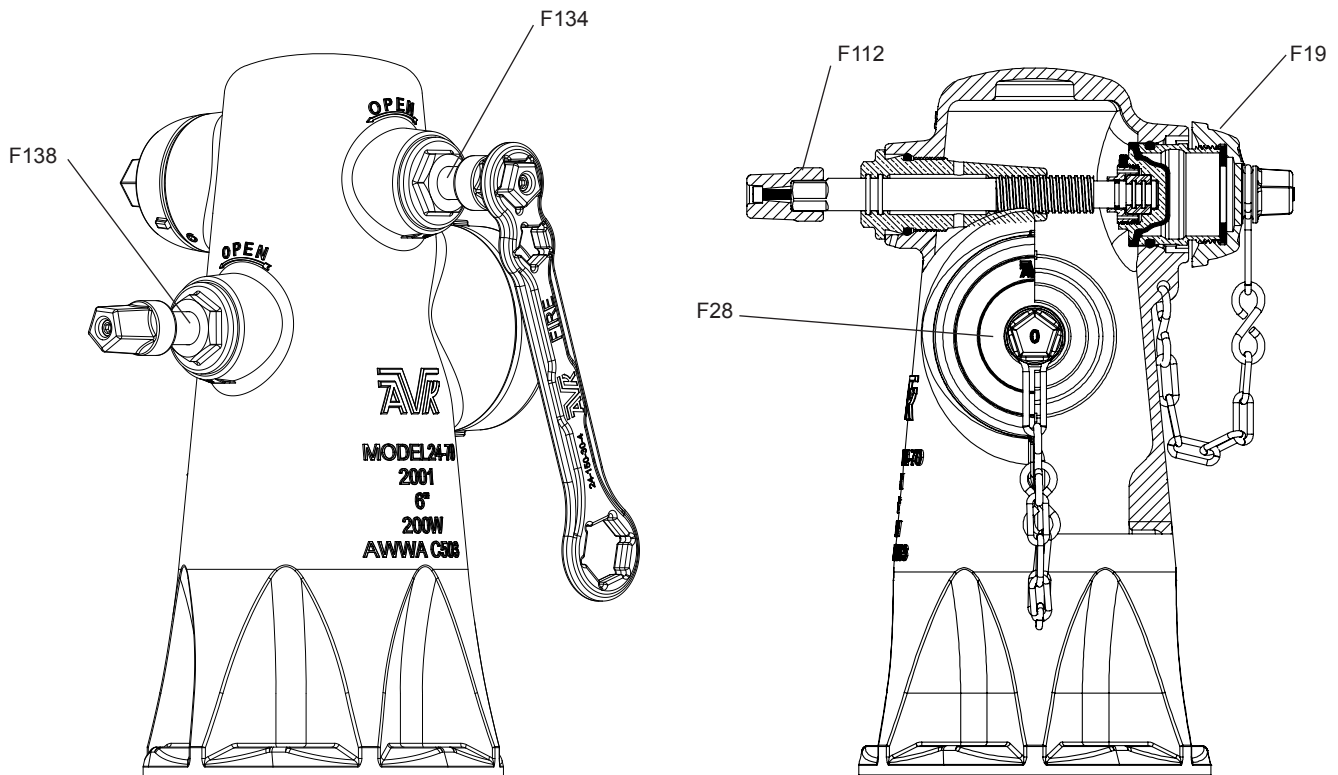

Fig. 2
Operation

INSPECTION

NOZZLE DISASSEMBLY FOR INSPECTION: FIGURES 3A-3J

If inspection of the fire hydrant is required, follow the DISASSEMBLY FOR INSPECTION instructions.

WARNING: For all of the following repair procedures, the hydrant must be isolated or the system depressurized and drained before removing the hydrant components. Failure to do so may cause pressure to be released resulting in severe injury or death.

NOZZLE INSPECTION

NOTE: If the hydrant is leaking from any of the nozzles, first try to determine if they are leaking from the Hose Cap Gasket (F115), or the Hose Nozzle O-ring (F22), and perform the applicable seal replacement procedure for the nozzle(s) in question.

Proper Nozzle Alignment:

1. Remove the Hose Nozzle Cap (F19), or Pumper Nozzle Cap (F28), using an AVK Hydrant Wrench or adjustable hydrant wrench.
2. Locate the Nozzle Retaining Screw (F23) hole. It is located approximately ½", in from the edge of the nozzle section and at about the 4:30 to 5:00 o'clock position when facing the nozzle.

NOTE: On 3 outlet wet barrel hydrants, the middle Nozzle Retaining Screw (F23) hole and fifth lug are oriented from the 9:00 o'clock position.

3. If the retaining screw is missing, ensure that the nozzle is correctly installed as shown in fig. "3G", (for Hose Nozzles), "3J", (for Pumper Nozzles), then immediately replace it (F23 - Nozzle Retaining Screw, M10mm x 16mm, 304 stainless steel).
4. For Hose Nozzles (F116), there should be a small "dimple" or punch mark on the hose nozzle. This mark should be in alignment with the Nozzle Retaining Screw (F23) as shown in figure "3G".
5. For Pumper Nozzles (F126), the "dimple" or punch mark is on the face of the cap end of the pumper nozzle as shown in figure "3J".
6. If the dimple is not in alignment with the retaining screw (F23), remove the retaining screw and rotate the nozzle until the alignment is correct.
7. Apply a drop of thread-locker (Loctite #242 or equal) to the end of the retaining screw, tighten it until it contacts the nozzle, and back off 1/8th of a turn.
8. Replace the hose nozzle cap (F19).
9. If required, repeat steps 1 through 8 for the other nozzles.

AVK hydrants manufactured before 2005 may not have the position marks ("dimples" or punch marks) on the hose and pumper nozzles. In this case, follow the following steps to add the indicators to ensure correct nozzle positioning:

1. Remove the hydrant nozzle caps.
2. Using a 3/16" or 5mm Allen wrench, remove the Nozzle Retaining Screws (F23).
3. Rotate the nozzles in a clockwise direction approximately 40 degrees until the nozzle slot aligns with lug opening on the nozzle section, located at the 6 o'clock position. See Fig. "3F".
4. Push the cap/nozzle assembly outward, by turning the valve in the closing direction, until the nozzle lugs are between the nozzle section lugs as shown in Fig. "3C".
5. Loosen the cap, then finish removing the cap/nozzle assembly.

NOTE: AVK hydrants manufactured after 2004 have a "fifth lug" located at the 6 o'clock position in the outlets. This prevents the nozzles from being installed with the slotted lug in the wrong location.

6. Using a pointed punch and a hammer, stamp a small dimple into the surface of the nozzles as shown in figures "3F & 3J". The small dimple must be located on the center line of the "split" lug on the bronze nozzles.
7. Mark the dimples with a permanent ink marker to make the marks easily visible.
8. Follow the steps in "REASSEMBLY AFTER INSPECTION", to reinstall the nozzles and caps.

INSPECTION

NOZZLE DISASSEMBLY FOR INSPECTION (continued):

WARNING: For all of the following repair procedures, the hydrant must be isolated or the system depressurized and drained before removing the hydrant components. Failure to do so may cause pressure to be released resulting in severe injury or death.

Nozzle leaking from around the Nozzle Cap:

NOTE: AVK wet barrel hydrants have cap gaskets that are designed to allow residual water to drain from the caps. Perform the following steps if water is leaking continuously from a nozzle.

1. Cycle the valve open then fully closed. See if residual water stops draining from the hydrant.
2. Verify that the valve is closed. Carefully remove the Hose Nozzle Cap (F19, or Pumper Nozzle Cap (F28), and Hose Nozzle Cap Gasket (F115), or Pumper Nozzle Cap Gasket (F120), using an AVK Hydrant Wrench or adjustable hydrant wrench.
3. Visually inspect the valve assembly for any damage or foreign material trapped between the valve and nozzle. If foreign material is present, open the valve and remove the material.
4. If the rubber on the Valve Disc is damaged, refer the "VALVE DISC DISASSEMBLY FOR INSPECTION" and "VALVE DISC REASSEMBLY FOR INSPECTION", sections of this manual for corrective action.
5. When the problem has been corrected, lightly grease the nozzle threads with a food grade grease that contains no acetate or silicone, and replace the cap and gasket assembly.
6. Pressurize the hydrant and verify that the leaking has stopped.

Nozzle leaking from around the Nozzle O-ring area:

1. Remove the Nozzle Retaining Screw (F23) using a 3/16" or 5mm Allen wrench.
2. Rotate the nozzle in a clockwise direction approximately 40 degrees until the nozzle slot aligns with lug opening on the nozzle section, located at the 6 o'clock position of the desired outlet. See Fig. "3F".

NOTE: On 3 outlet wet barrel hydrants, the middle Nozzle Retaining Screw (F23) hole and fifth lug are oriented from the 9:00 o'clock position.

3. Push the cap/nozzle assembly outward, by turning the valve in the closing direction, until the nozzle lugs are between the nozzle section lugs as shown in Fig. "3C".
4. Loosen the cap, then finish removing the cap/nozzle assembly. (See Figs. 3D & 3E)
5. Remove the old Hose Nozzle O-ring (F22), or Pumper Nozzle O-ring (F25), and replace with a new one.
6. Lightly grease the o-ring with a food grade grease that contains no acetate or silicone.
7. Follow the steps in "REASSEMBLY AFTER INSPECTION", to reinstall the nozzles and caps.

NOZZLE REASSEMBLY AFTER INSPECTION:

1. Insert the greased Cap/Nozzle assembly into the nozzle section outlet until the nozzle lugs are in line with the nozzle section lugs as shown in Fig. 3C.
2. Tighten the cap on the nozzle. Insert the cap/nozzle assembly fully into the nozzle section and using a hydrant wrench.

NOTE: The valve may have to be turned in the opening direction to allow the nozzle to be inserted fully.

3. Slowly rotate the cap/nozzle assembly counter clockwise, approximately 40 degrees, until the slotted nozzle lug aligns with the Nozzle Retaining Screw hole. This can be verified by lining up the dimple with the Nozzle Retaining Screw hole.
4. Apply a drop of thread-locker (Loctite #242 or equal) to the end of the retaining screw, and using a 3/16" or 5mm Allen wrench, tighten it until it contacts the nozzle, and back off 1/8th of a turn.
5. Verify that the Cap has been secured.
6. Verify that all outlets have been fully closed.
7. Once the hydrant has been completely reassembled, turn on the supply valve to check for leaks.

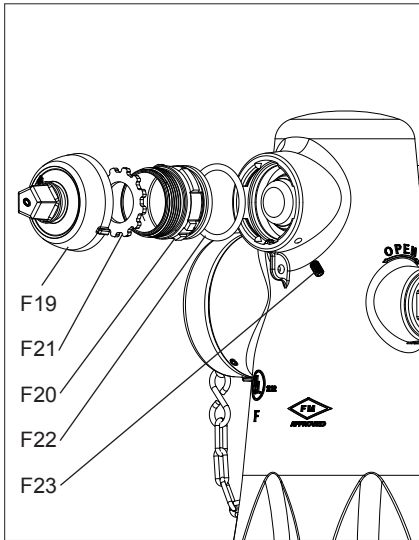

Fig. 3A

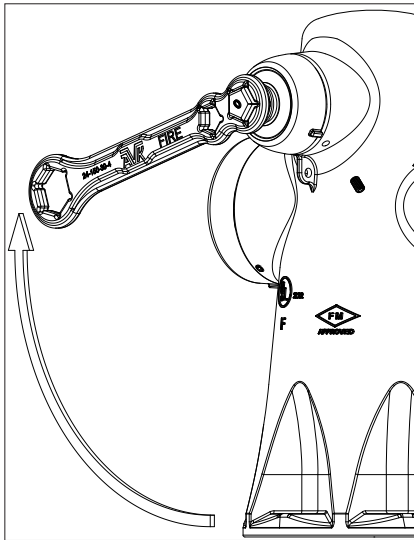

Fig. 3B

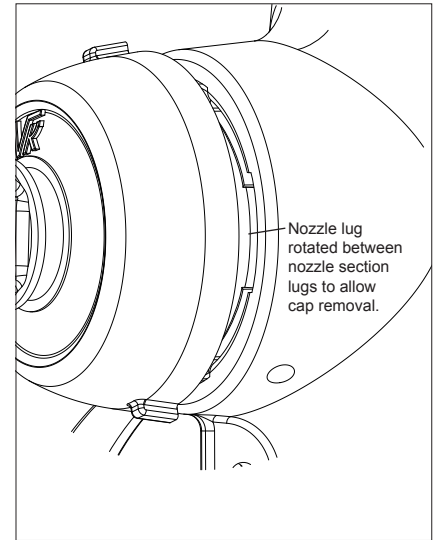

Fig. 3C

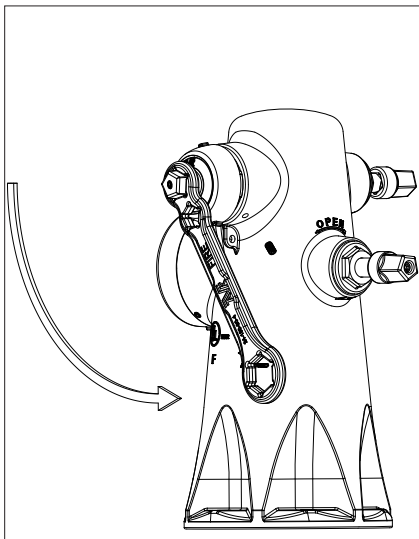

Fig. 3D

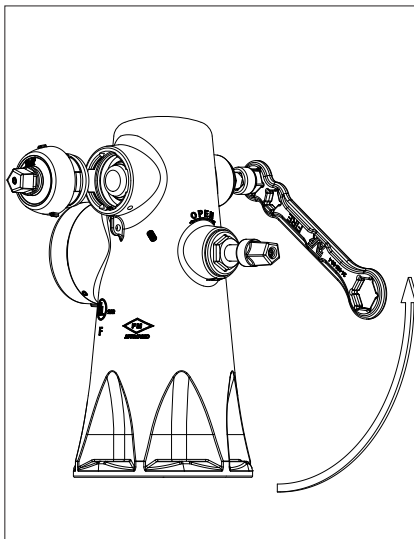

Fig. 3E

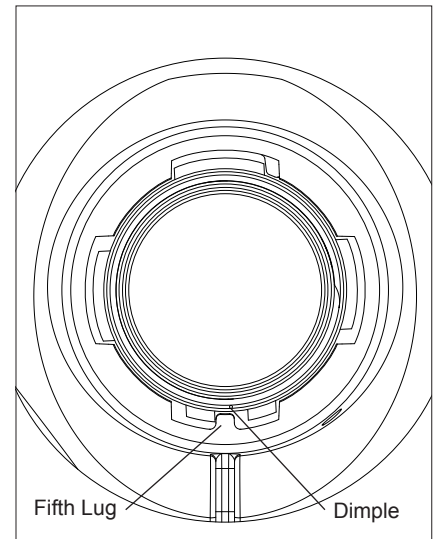

Fig. 3F

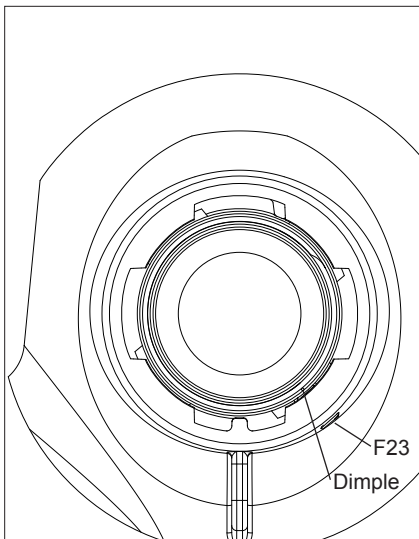

Fig. 3G

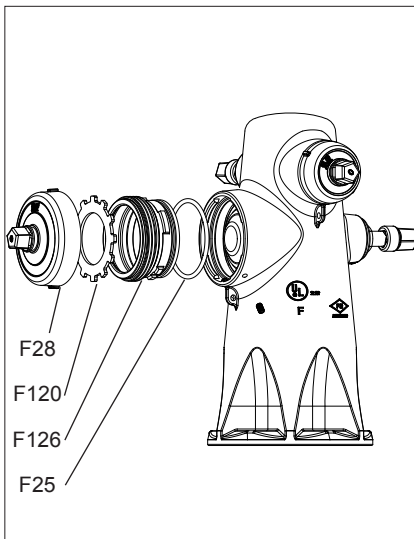

Fig. 3H

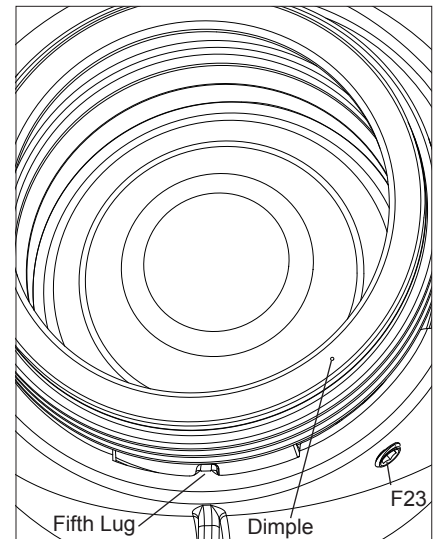

Fig. 3J

INSPECTION

VALVE DISC DISASSEMBLY FOR INSPECTION: FIGURES 4A-4E

WARNING: For all of the following repair procedures, the hydrant must be isolated or the system depressurized and drained before removing the hydrant components. Failure to do so may cause pressure to be released resulting in severe injury or death.

CAUTION: Shut off the Water Main Supply Valve and release the internal pressure to the Hydrant by removing the lowest Pumper Nozzle Cap (F28), and slightly open the outlet valve to allow any residual water to drain from the hydrant. The hydrant is now ready for service.

VALVE DISC INSPECTION

Nozzle leaking from around the Valve Disc:

NOTE: The following steps may be required if the rubber surface of the Valve Disc is damaged. If the Valve Disc is not damaged, inspect the hose or pumper nozzle for damaged sealing surfaces and replace if necessary. Refer to the NOZZLE DISASSEMBLY and REASSEMBLY sections of this manual.

1. Use the AVK Hydrant Wrench or an adjustable hydrant wrench to remove the Hose Nozzle Cap (F19), or Pumper Nozzle Cap (F28) for the valve that is being serviced.
2. Using a 3/16" or 5mm Allen wrench, remove the Nozzle Retaining Screw (F23).
3. Rotate the nozzle in a clockwise direction approximately 40 degrees until the nozzle slot aligns with lug opening on the nozzle section, located at the 6 o'clock position on 2 outlet hydrants, or 9 o'clock position on the middle outlet on 3 outlet hydrants. See Fig. "3F", page10.
4. Push the cap/nozzle assembly outward, by turning the valve in the closing direction, until the nozzle lugs are between the nozzle section lugs as shown in Fig. "3C", page10.
5. Loosen the cap, then finish removing the cap/nozzle assembly.
6. Using a 15/64" or (6mm) Allen wrench, remove the Dummy Nut Retaining Bolt (F113) and Dummy Nut (F112). See Fig. "4A"
7. The Valve Stem (F134 for 2.5" Valve Stem), (F138 for 4"-4.5" Valve Stem) can now be unscrewed, (In the closing direction.), from the Stem Nut (F110) and removed from the Nozzle Section (F101). See Figs. "4A & 4B".
8. At this time, it is recommended the Inner Stem Nut O-rings (F111) and the Nozzle O-rings (F25 for Pumper Nozzle O-ring) and (F22 for Hose Nozzle O-ring) be replaced.
9. Use a 7/64" or (3mm) Allen wrench and remove the Stem Nut/Thrust Nut Retaining Screw (F114). The Valve Disc (F133, for 2.5"), or (F137, for 4"-4.5"), can be removed from the Thrust Nut (F135, for 2.5") or (F139, for 4"-4.5"), by unscrewing the valve disc from the thrust nut. See Fig. "4C"
10. Push the thrust nut towards the threads and remove the Thrust Collars, (F136 for 2.5"), or (F140 for 4"-4.5"). See Fig. "4D"
11. Remove the Thrust Nut (F135, for 2.5") or (F139, for 4"-4.5"), from the Valve Stem (F134, for 2.5"), (F137, for 4"-4.5"). See Fig. "4D"
12. Remove the Thrust Nut O-ring (F141, for 2.5") or (F142 for 4"-4.5") valve stems. See Fig. "4E"

VALVE DISC REASSEMBLY AFTER INSPECTION:

1. Replace the Thrust Nut O-ring, (F141, for 2.5") or (F142 for 4"-4.5") valve stems. These o-rings act as a brake, **DO NOT** grease the o-rings. Wipe off any grease that may have gotten on the o-ring during assembly. The 4"-4.5" Thrust Nut O-ring is larger than the 2.5" Thrust Nut O-ring.
2. Slide the thrust nut over the stem end that has the o-ring. The threads of the thrust nut need to point toward the short end so the valve disc can be threaded on it. Push the thrust nut over the o-ring to make room for the thrust collars.
3. Grease the inside grooves of the Thrust Collar (F136 for 2.5"), or (F140 for 4"-4.5") with a food grade grease that contains no acetate or silicone. Install the Thrust Collar over the grooves of the stems. The 4"-4.5" Thrust Collars are larger than the 2.5" Thrust Collars. Avoid getting grease on the o-ring. Wipe off grease that may have gotten on the o-ring.
4. Pull the thrust nut up over the collars until it stops.
5. Screw the valve disc and thrust nut together until hand tight. Then use the appropriate hand tools to tighten.
6. Apply a drop of thread-locker (Loctite #242 or equal), to the end of the Stem Nut/Thrust Nut Retaining Screw (F114), and screw into the hole on the side of the valve disc and tighten with a 7/64" or (3mm) Allen wrench.

VALVE DISC REASSEMBLY AFTER INSPECTION: (continued):

Note: The disc should not spin freely on the stem. The o-ring should act as a brake.

CAUTION: The valve disc assemblies should be tight enough to prevent linear movement on the stem, but loose enough that you can rotate the assembly on the stem by hand.

7. **DO NOT** grease the ACME threads of the stems. Put food grade grease, that contains no acetate or silicone, on the inside threads of the Stem Nut (F110), then screw the stem/valve disc assembly into the Stem Nut.
8. Place a Dummy Nut (F112) onto the pentagon of stem and secure it with a Dummy Nut Retaining Bolt (F113) that has a drop of thread-locker (Loctite #242 or equal), on it. Tighten the bolt with 15/64" or (6mm) Allen wrench.
9. Follow the steps in "NOZZLE REASSEMBLY AFTER INSPECTION", on page 9 to re-install the Nozzle/Cap assembly.

NOTE: Hydrants manufactured between July, 1998 through May, 2006, with the older style multi piece Valve Disc/Stem assembly can be retrofitted with the new style Valve Disc/Stem assembly. Hydrants manufactured prior to July, 1998 are not compatible. Contact AVK Customer Service for replacement parts, or hydrants.

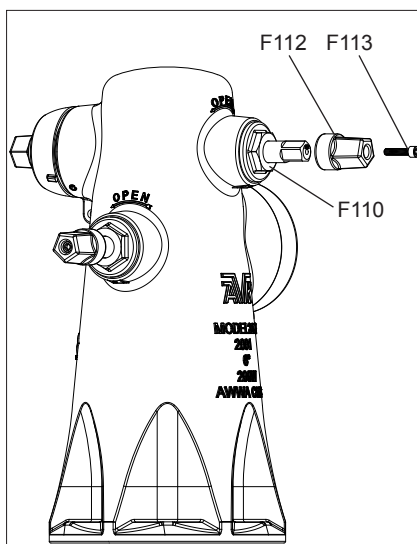

Fig. 4A

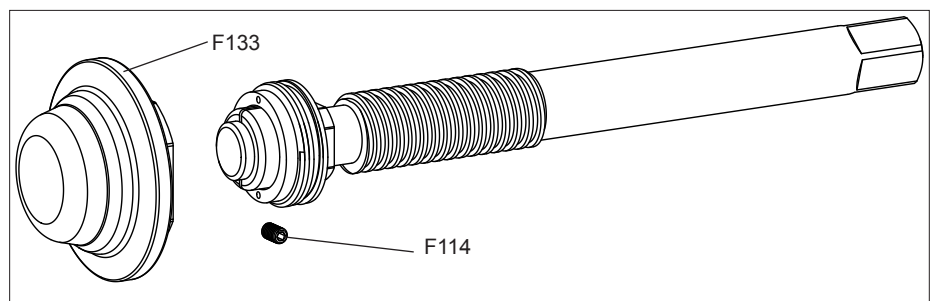

Fig. 4C

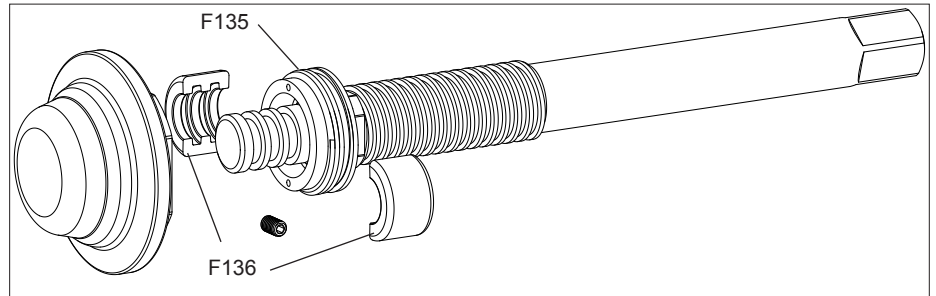

Fig. 4D

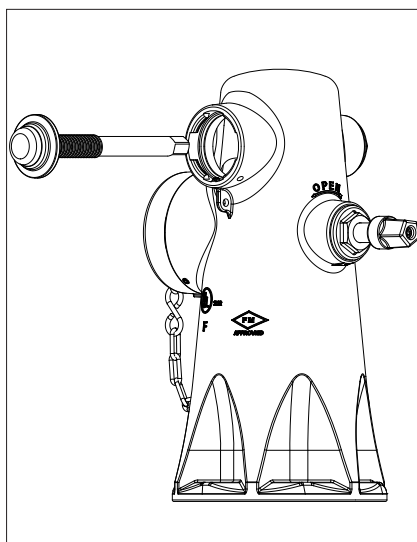

Fig. 4B

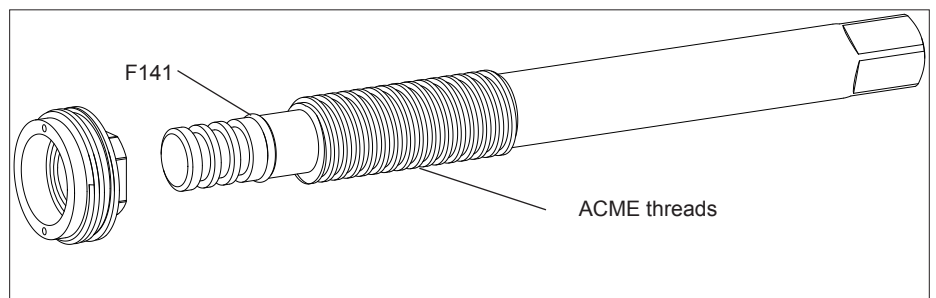

Fig. 4E

INSPECTION

STEM NUT DISASSEMBLY FOR INSPECTION: FIGURES 5A-5E

STEM NUT / STEM NUT O-RING REPLACEMENT

WARNING: For all of the following repair procedures, the hydrant must be isolated or the system depressurized and drained before removing the hydrant components. Failure to do so may cause pressure to be released resulting in severe injury or death.

1. Using a 15/64" or (6mm) Allen wrench, remove the Dummy Nut Retaining Bolt (F113) and Dummy Nut (F112). See Fig. "5A"
2. Use a 7/64" or (3mm) Allen wrench and remove the Stem Nut Retaining Screw (F114). See Fig. "5B"
3. Using an AVK Hydrant Wrench or adjustable wrench, unscrew the Stem Nut (F110) in a counterclockwise direction. The Inner Stem Nut O-rings (F111) and Outer Stem Nut O-ring (F109) can now be inspected and replaced if necessary. See Figs. "5C&5D"
4. When re-installing the Stem Nut (F110) apply a thin coat of food grade grease or oil, that contains no acetate or silicone, to the o-rings (F109,F111) . Also take care to avoid cross threading the Stem Nut threads in the ductile iron Nozzle Section. Apply a drop of thread-locker (Loctite #242 or equal), to the end of the Stem Nut/Thrust Nut Retaining Screw (F114), and tighten with a 7/64" or (3mm) Allen wrench. See Fig. "5B&5E"
5. Apply a drop of thread-locker (Loctite #242 or equal), and re-install the Dummy Nut and Dummy Nut Retaining Bolt.

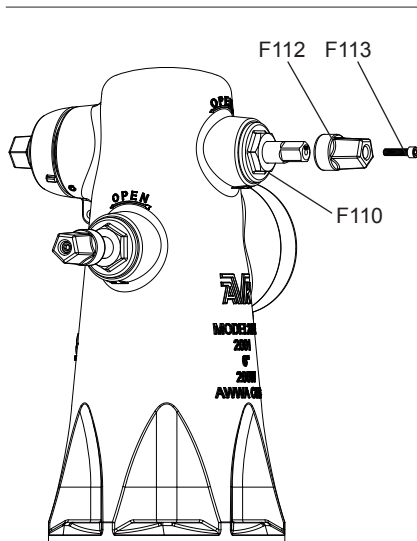

Fig. 5A

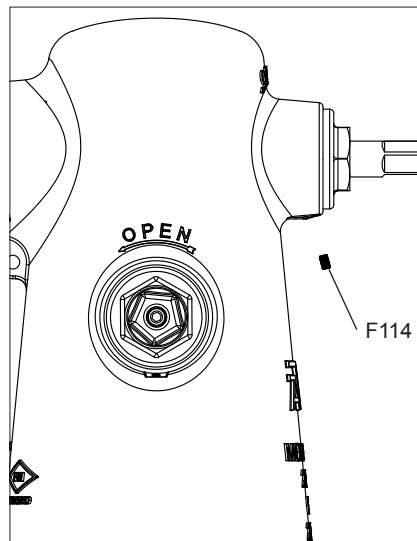

Fig. 5B

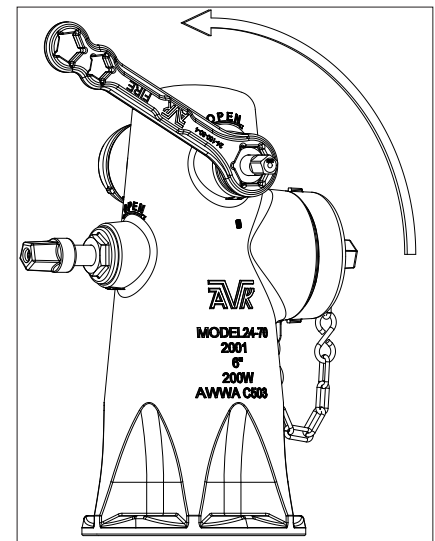

Fig. 5C

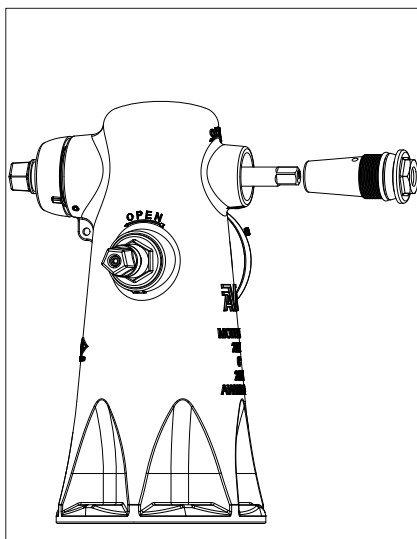

Fig. 5D

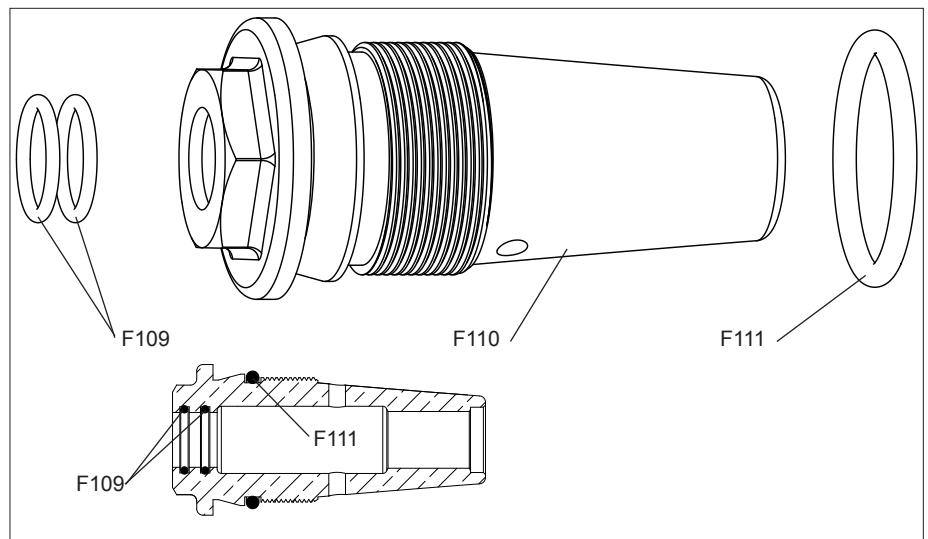

Fig. 5E

REPAIR PROCEDURES

TRAFFIC REPAIR:

AVK Wet Barrel Hydrants feature a safety Breakable Flange Unit design. This allows the hydrant head assembly to be struck by a vehicle and “Break Away” reducing the impact to the water main. In the event the hydrant head assembly has been broken away, the following repairs will be necessary.

WARNING: For all of the following repair procedures, the hydrant must be isolated or the system depressurized and drained before removing the hydrant components. Failure to do so may cause pressure to be released resulting in severe injury or death.

1. Remove any mounting hardware, the old Wet Barrel Flange O-ring (F123), broken Break Ring (F124) pieces, and discard.
2. Place the new Wet Barrel Flange O-ring in the groove of the Wet Barrel Flange Section (F127). Place the Hydrant Nozzle Section Assembly on the Flange Section and align the holes.
3. Install the Nozzle Section Bolts (F122), (with a new Nozzle Section Washer (F31) beneath the head of each bolt), into six mounting holes. (See Fig. 6)
4. Place the two halves of the Break Ring (F124) together below the lip of the Flange Section (F127) and lift upward until the bolts project down through the holes in the new Break Ring halves.

NOTE: The cut away view of the Break Ring shows orientation with the outer flange pointing upward.

5. Place the new Nozzle Section Washers (F31) and Nozzle Section Nuts (F125) on the bolts, beginning with the two overlapping holes that mate the two halves of the Break Ring pair.
6. With a 15/16” or (24mm) wrench tighten the nuts in a diametric pattern (180 degrees apart) to apply a uniform torque evenly around the new Break Ring.

CAUTION: Maximum torque on the nuts must not exceed 60 foot pounds.

7. Re-pressurize the hydrant slowly, bleeding off any trapped air, to prevent air pressure from blowing out the new gasket or water hammer from breaking the new Break Ring or damaging the water system

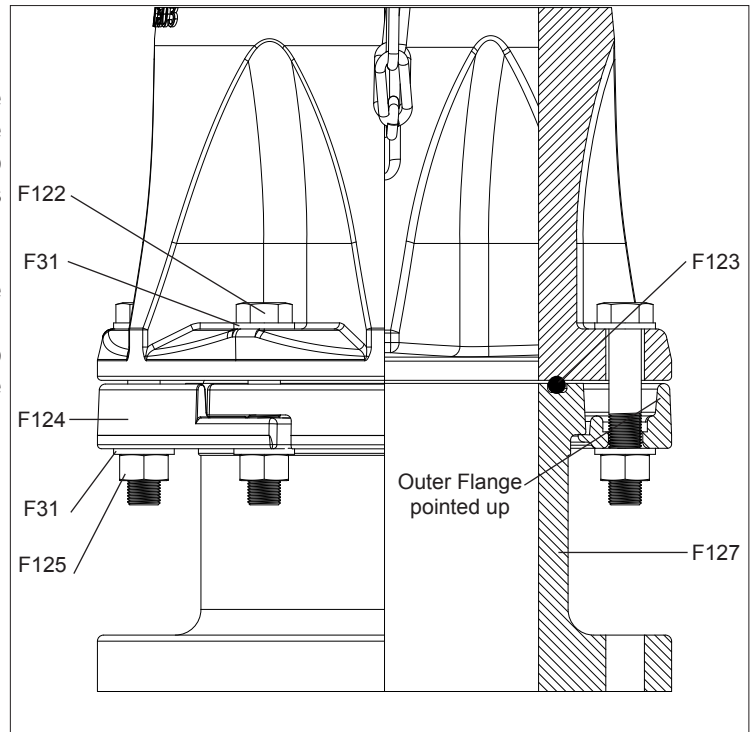

Fig. 6

OPTIONAL EQUIPMENT FLOWGUARD II ®

WARNING: For all of the following repair procedures, the hydrant must be isolated or the system depressurized and drained before removing the hydrant components. Failure to do so may cause pressure to be released resulting in severe injury or death.

1. Turn the Body (F128) up-side-down and set it down. The cast-in flow arrow should be pointing toward the Hard stable surface. Place the Ball (F132), into the Body.
2. Install the 8mm thick Seat Ring O-ring (F144), (the thickest of the three o-rings in the kit) onto the stainless steel Lower Seat Ring (F130), and grease the o-ring with a food grade grease that contains no acetate or silicone.
3. Place the Lower Seat Ring into the body and press into place. Ensure that the O-ring remains in it's proper location.
4. Use food grade grease that contains no acetate or silicone, to stick the Lower O-ring (F145), in the groove between the Body and the Lower Seat Ring.
5. Carefully turn the assembly over and place it on the mounting flange of the riser pipe and attach loosely with mounting hardware. The bolts should be installed from the bottom so that with the nuts are on top of the check valve flange.
6. Place the Upper Retaining Cage (F129) into the top of the assembly and install the Upper O-ring (F143) into the groove created between the Body and Upper Retaining Cage.
7. Carefully mount the Wet barrel assembly onto the FlowGuard II assembly with the Breakable Flange (F124) and mount with the mounting hardware as shown in Fig. 7B and Fig. 7C.
8. Carefully rotate the Wet barrel to the desired position. Do not dislodge the Upper O-ring, and tighten all mounting hardware to 60 Ft. Lbs. .

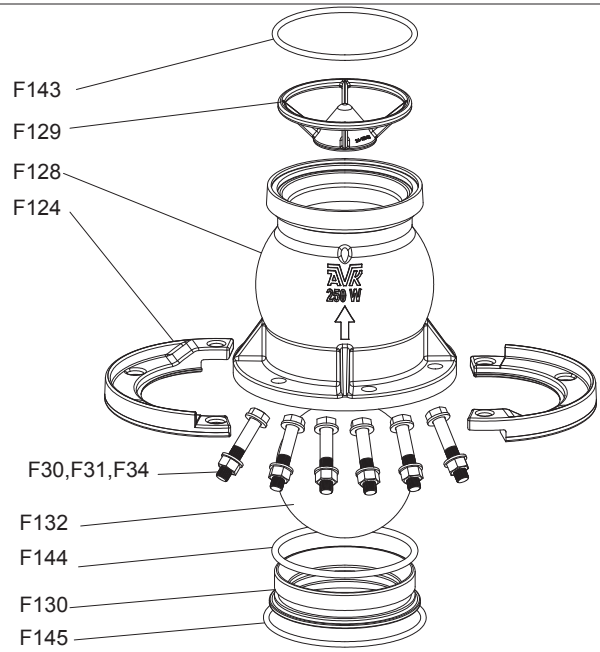

Fig. 7A

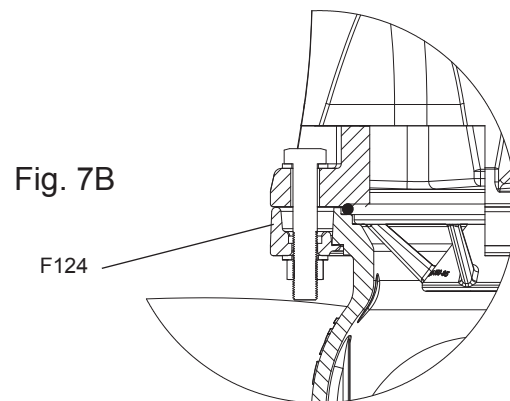

Fig. 7B

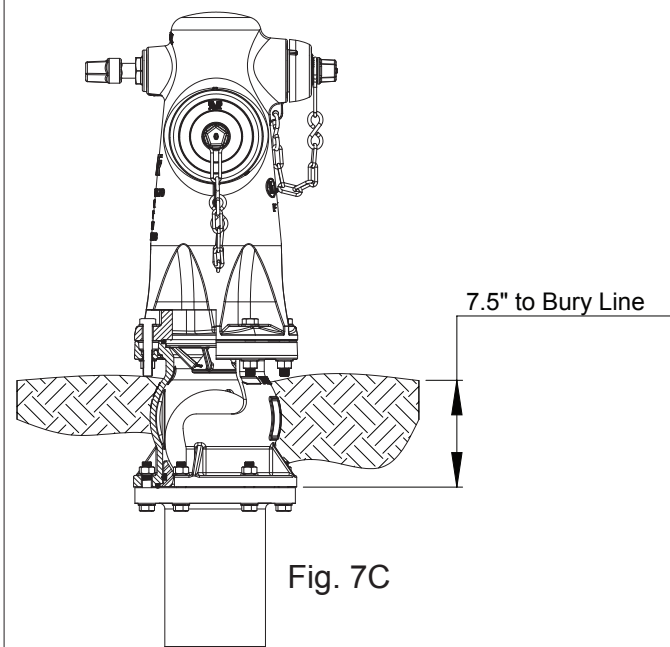

Fig. 7C

TROUBLESHOOTING GUIDE

PROBLEM: Hydrant leaking from around nozzle.

Probable Cause: Damaged valve disc or nozzle sealing surface.

Corrective action: Inspect valve disc and nozzle sealing surfaces and replace if necessary.

PROBLEM: Hydrant leaking from around stem nut.

Probable Cause: Damaged stem o-rings.

Corrective action: Replace stem o-rings.

PROBLEM: Nozzle section facing the wrong direction.

Corrective action: Loosen the Nozzle Section hardware and carefully rotate the Nozzle Section to the desired position. Tighten the mounting hardware to 60 Ft. Lbs..

PROBLEM: Hydrant flow is low.

Probable Cause: Hydrant or supply valve is not fully open.

Corrective action: Verify that the hydrant is fully open. The AVK Series 24 hydrant valve discs are fully opened in approximately 9-14 turns.
Also locate and verify that the supply valve is fully open.

PARTS AND SERVICE

For information on parts and service for your area contact American AVK. Make a note of the valve model number and size located on the valve and contact:

American AVK Company

2155 N. Meridian Blvd.
Minden, NV 89423
PH: 775-552-1400
FAX: 775-783-7502
www.americanavk.com

**AMERICAN AVK COMPANY WARRANTY
SERIES 24 WET BARREL HYDRANTS**

American AVK Company warrants all models of Series 24 Wet Barrel Fire Hydrants to be free from defects in workmanship and materials for a period of ten (10) years from the date of shipment from American AVK Company. American AVK Company shall have no obligation under this warranty unless it is notified of claims hereunder promptly and in writing upon discovery thereof and within the warranty period, and unless the product is delivered to an American AVK Company facility within thirty (30) days of such notice.

American AVK shall have the right to inspect said product before it is removed from installation. If the product is removed from installation prior to approval from American AVK this warranty shall be void.

As to motors, gearing or accessory equipment purchased by American AVK Company from others manufacturers, and used or incorporated into American AVK Company's products, those manufacturers' warranties shall apply.

American AVK Company will honor all reasonable costs to repair or replace any American AVK Company Wet Barrel Fire Hydrant found to be defective.

American AVK Company's sole responsibility shall be, in its sole discretion, to replace the product with the same or a similar product, repair the product, or refund the price paid for the product provided the product has been properly applied and used under normal service and under conditions for which it is designed. American AVK Company shall not be liable for indirect, special, incidental, or consequential damage or penalties and does not assume any liability of purchase to others or to anyone for injury to persons or property.

THIS IS THE EXCLUSIVE WARRANTY GIVEN IN CONNECTION WITH THE SALE OF THIS PRODUCT. THERE ARE NO OTHER WARRANTIES, EXPRESSED OR IMPLIED, INCLUDING EXPRESSED OR IMPLIED WARRANTY OF MERCHANTABILITY, OR ANY EXPRESSED OR IMPLIED WARRANTY OF SUITABILITY FOR ANY PARTICULAR PURPOSE, GIVEN BY AMERICAN AVK COMPANY IN CONNECTION WITH THIS PRODUCT.

PARTS AND SERVICE

For information on parts and service for your area contact American AVK. Make a note of the valve model number and size located on the valve and contact:

American AVK Company

2155 N. Meridian Blvd.

Minden, NV 89423

PH: 775-552-1400

FAX: 775-783-7502

www.americanavk.com

AMERICAN AVK COMPANY WARRANTY

SERIES 2488 FlowGuard II ®

American AVK Company warrants its Series 2488 FlowGuard II to be free from defects in workmanship and materials for a period of one (1) year from the date of shipment from American AVK Company. American AVK Company shall have no obligation under this warranty unless it is notified of claims hereunder promptly and in writing upon discovery thereof and within the warranty period, and unless the product is delivered to American AVK Company within thirty (30) days of such notice.

American AVK shall have the right to inspect said product before it is removed from installation. If the product is removed from installation prior to approval from American AVK this warranty shall be void.

As to motors, gearing or accessory equipment purchased by American AVK Company from other manufacturers, and used or incorporated into American AVK Company's products, those manufacturers' warranties shall apply.

American AVK Company's sole responsibility shall be, in its sole discretion, to replace the product with the same or a similar product, repair the product, or refund the price paid for the product provided the product has been properly applied and used under normal service and under conditions for which it is designed. American AVK Company shall not be liable for indirect, special, incidental, or consequential damage or penalties and does not assume any liability of purchase to others or to anyone for injury to persons or property.

THIS IS THE EXCLUSIVE WARRANTY GIVEN IN CONNECTION WITH THE SALE OF THIS PRODUCT. THERE ARE NO OTHER WARRANTIES, EXPRESSED OR IMPLIED, INCLUDING EXPRESSED OR IMPLIED WARRANTY OF MERCHANTABILITY, OR ANY EXPRESSED OR IMPLIED WARRANTY OF SUITABILITY FOR ANY PARTICULAR PURPOSE, GIVEN BY AMERICAN AVK COMPANY IN CONNECTION WITH THIS PRODUCT.